

| FDS-tools.com

fds

Drill Rig **LB 36-410** Liebherr



47 Paterson Road
Oro-Medonte, ON
CANADA, L3V 0R4

1904 Tollgate Road
Palm
USA, 18070

FDS Foundation Drilling Services Inc.

Delivering Certainty

Drilling Rig

LB 36-410

Litronic®

EN

LB 2005.05



LIEBHERR

Concept and characteristics

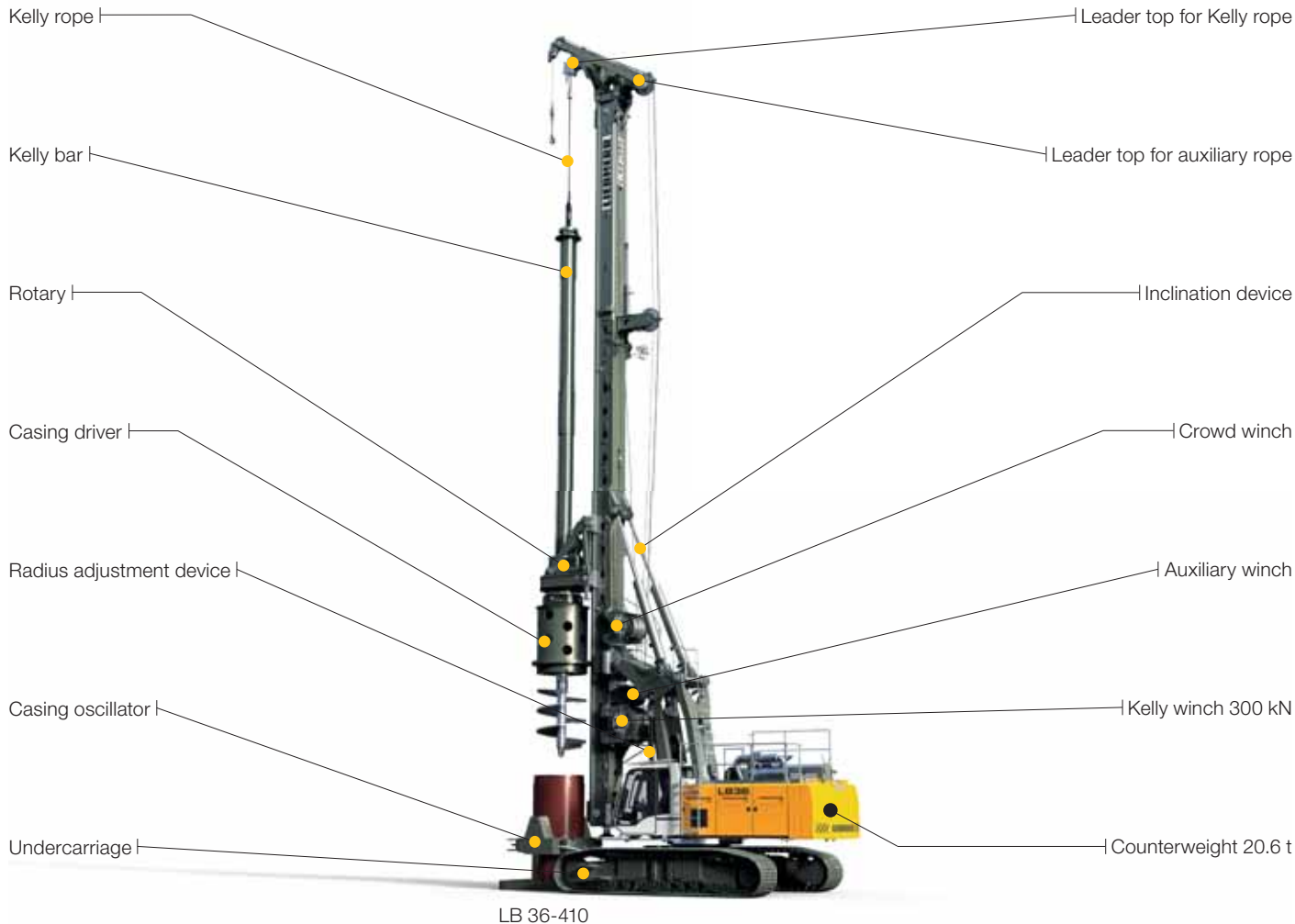

The robust universal machine for a wide variety of applications:

- Kelly drilling
- Auger drilling
- Full displacement drilling
- Double rotary drilling

The solid undercarriage offers excellent stability and low ground bearing pressure.

The uppercarriage with its small swing radius enables operation in restricted space.

Parallel kinematics with a large working area allow to fold back the leader.

The rigid leader absorbs high torque and is fitted with a rope crowd system for high pull forces.

All winches are mounted on the leader, which provides a direct view of the main winch from the operator's cab.

The rotary drive of the BAT series combines exceptional torque with optimum operating comfort.

The powerful Liebherr diesel engine is low in emission and economical through SCR technology.

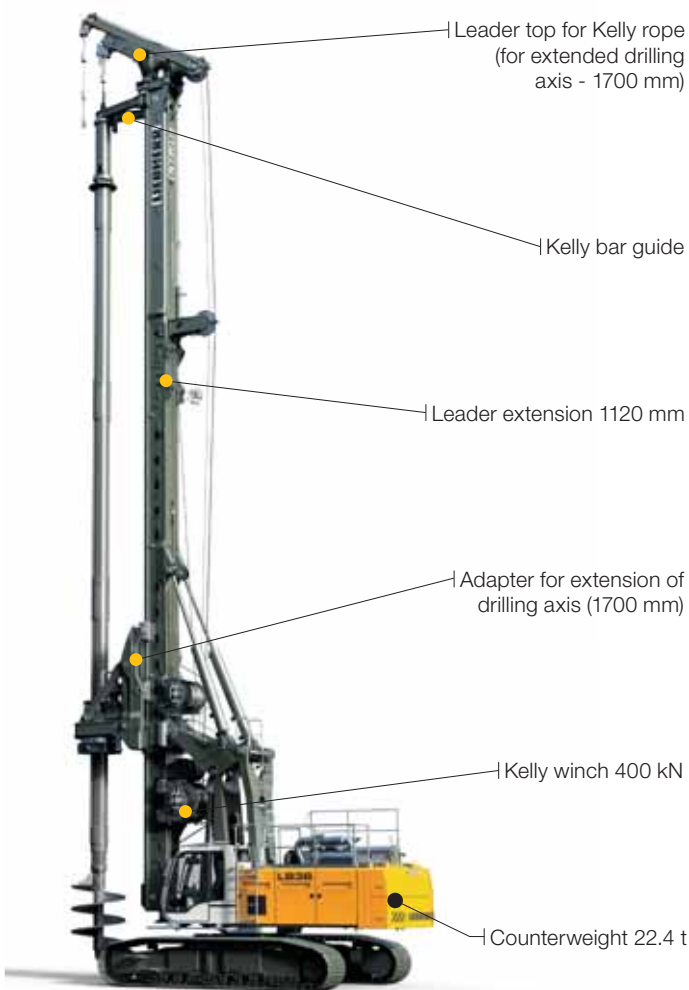

LB 36-410 with optional equipment

The Litronic control with assistance systems supports the operator:

- Cruise Control for the drilling process
- Joystick control for all machine functions
- Automatic shake-off function for working tools
- Leader inclination memory etc.

Sophisticated solutions provide safe operation and maintenance of the machine.

- Cab design for optimum visibility
- Acoustic and optic warning
- Walkways on the uppercarriage
- Safety rails on top of the uppercarriage
- Rear and side view cameras etc.

Liebherr Kelly bars feature strongly overlapping elements resulting in less wear.

Precise and robust Liebherr casings and drilling tools provide excellent drilling performance.

Dimensions

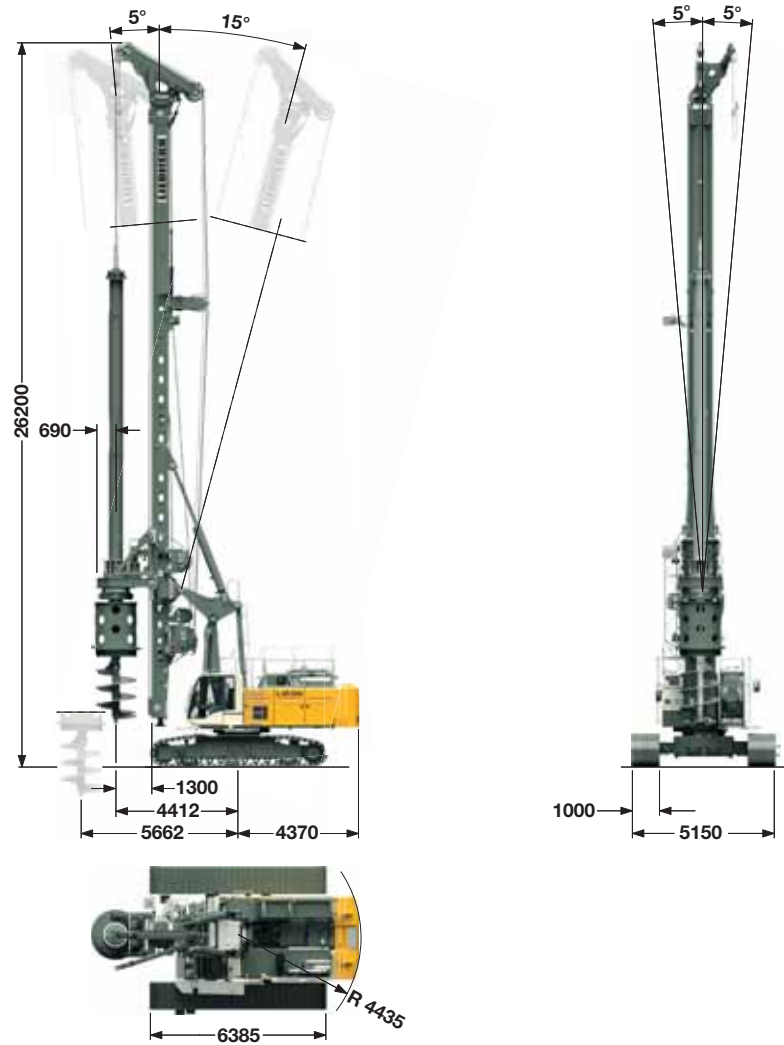

Technical data LB 36-410

Total height	26.2 m
Continuous rig inclination adjustment	
Lateral inclination	± 5°
Forward inclination	5°
Backward inclination	15°

Operating weight

Total weight with 900 mm 3-web shoes	115.0 t
with 1000 mm 3-web shoes	115.7 t

The operating weight includes the basic machine LB 36-410 (with rotary and Kelly bar MD 36/3/30) and 20.6 t counterweight, without equipment for casing oscillator.

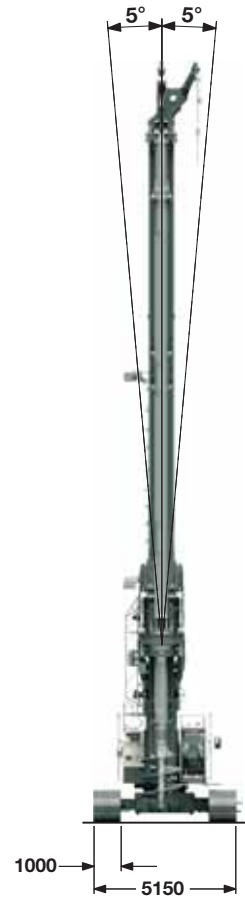
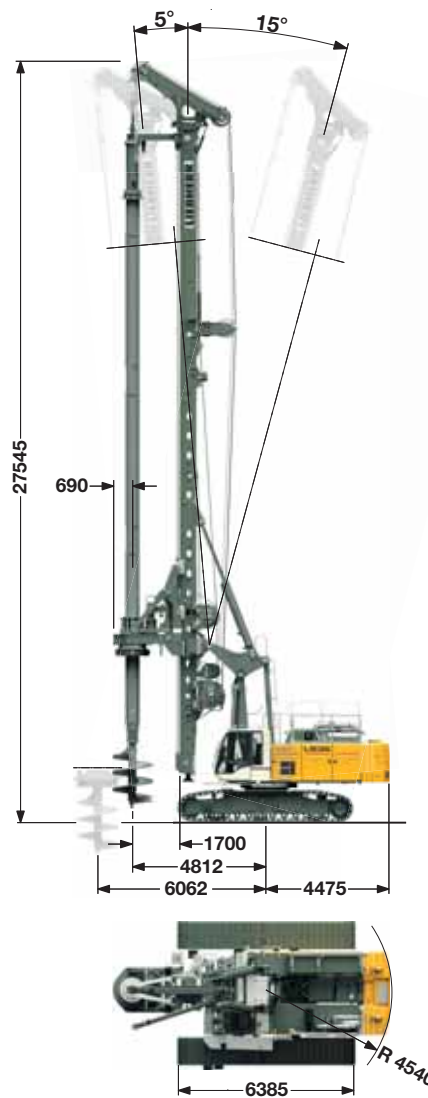

Technical data LB 36-410 with optional equipment

Total height	27.54 m
Continuous rig inclination adjustment	
Lateral inclination	± 5°
Forward inclination	5°
Backward inclination	15°

Operating weight

Total weight with 900 mm 3-web shoes	125.6 t
with 1000 mm 3-web shoes	126.3 t

The operating weight includes the basic machine LB 36-410 (with rotary and Kelly bar MD 36/4/54) and 22.4 t counterweight, without equipment for casing oscillator.

Transport dimensions and weights

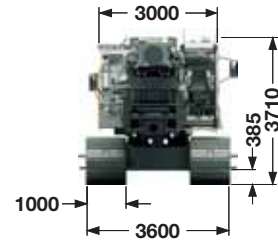
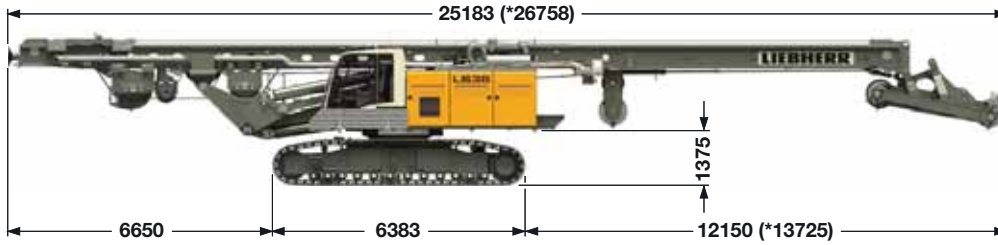

Transport standard

includes the basic machine (ready for operation) with leader, without working tools (such as rotary, Kelly bar etc.) and without counterweight.

Dimensions and weights

Length ————— 25.18 m

Weight complete without counterweight ————— (*80.3) 78.6 t

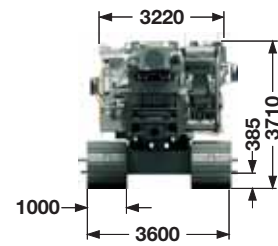
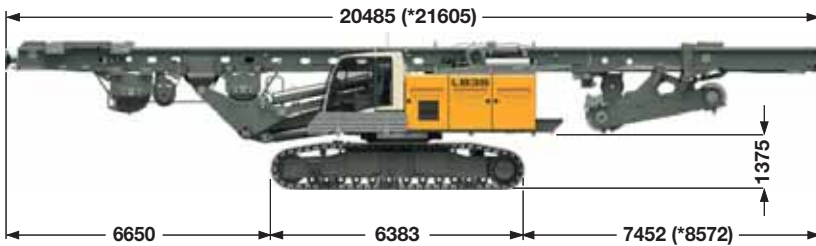

Transport option leader folded

includes the basic machine (ready for operation) with leader, without working tools (such as rotary, Kelly bar etc.) and without counterweight.

Dimensions and weights

Length ————— 20.48 m

Weight complete without counterweight ————— (*80.7) 79.0 t

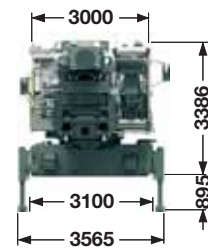
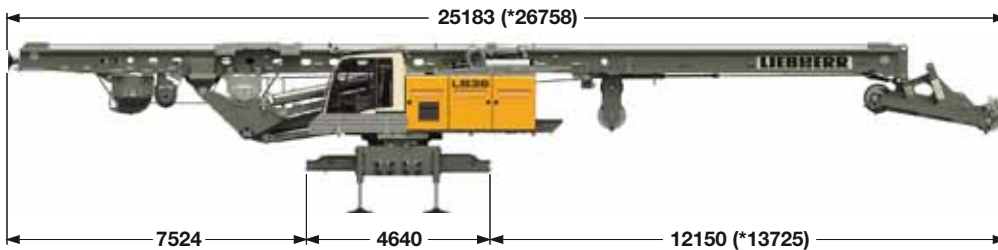

Transport without crawlers

includes the basic machine (ready for operation) with leader, without working tools (such as rotary, Kelly bar etc.), without crawlers and without counterweight.

Dimensions and weights

Length ————— 25.18 m

Weight complete without counterweight ————— (*61.7) 59.9 t

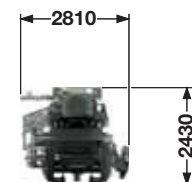
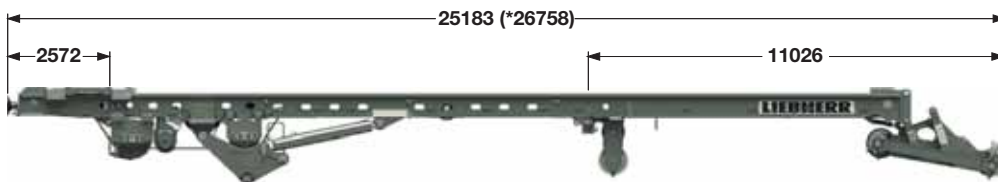

Transport leader

includes the leader without working tools (such as rotary, Kelly bar etc.).

Weights

Weight complete ————— (*29.1) 27.3 t

Lower part of the leader ————— 1.5 t

Upper part of the leader with leader top ————— (*4.8) 4.6 t

*) Rigs with optional equipment
The figures in this brochure may include options which are not within the standard scope of supply of the machine.

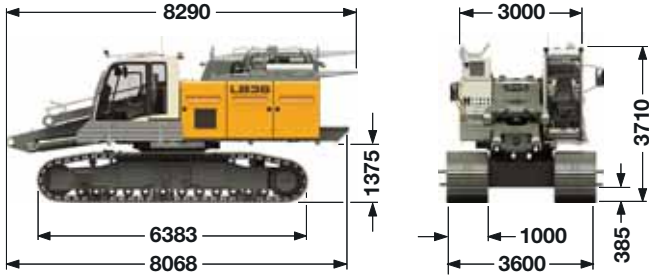

Transport basic machine

without counterweight.

Transport weight without self-assembly system — 51.2 t

Counterweight I



Counterweight II

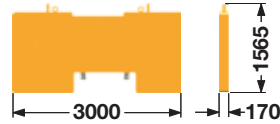

Counterweight I

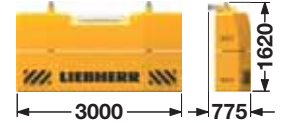

Counterweight II

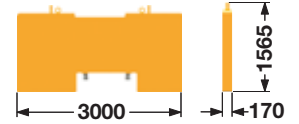

Counterweight (standard)

Counterweight I — 10.2 t

Counterweight II — 2x 5.2 t

Counterweight (optional equipment)

Counterweight I — 2x 6.0 t

Counterweight II — 2x 5.2 t

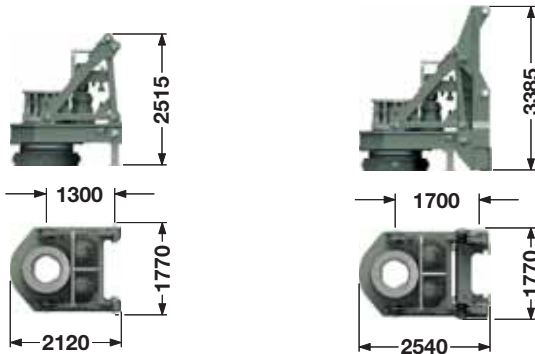

Rotary standard

Transport weight

BAT 410 — 9.1 t

Rotary with optional equipment

Transport weight

BAT 410 — 11.1 t

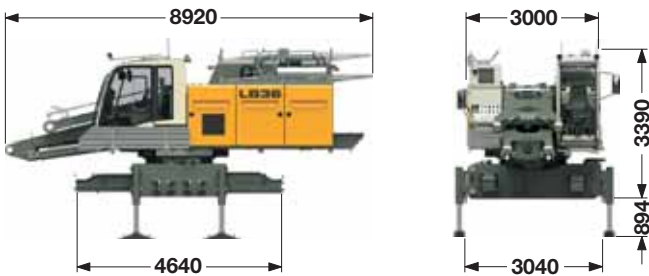

Transport basic machine

Ready for operation, without crawlers and without counterweight.

Transport weight — 32.6 t

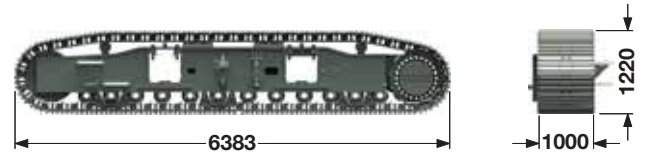

Crawlers

Crawler left — 10.1 t

Crawler right — 10.1 t

Weights can vary with the final configuration of the machine.

The figures in this brochure may include options which are not within the standard scope of supply of the machine.

Rotary BAT 410 with shock absorber



Automatic gearbox for best operating comfort

- No stopping required to change gears
- No interruption of the drilling process
- Automatic torque adjustment
- Continuous optimization of speed
- Four electronically adjustable speed ranges

Highest availability through easy set-up

- No mechanical shift gearbox
- Higher availability thanks to less moving parts
- Less maintenance required

- No pressure lubrication necessary
- No interferences through defective lubrication pump
- Simplified hydraulics
- Lower risk of hydraulics leakages

Flexibility through modular design

- Exchangeable drive adapters for use of other Kelly bars
- Exchangeable cardan joint for other casing drivers
- Quickly exchangeable equipment for other methods of operation

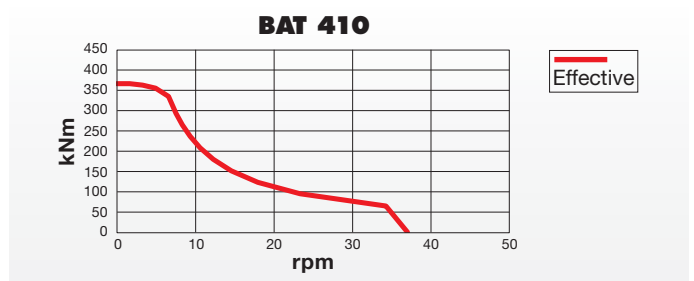
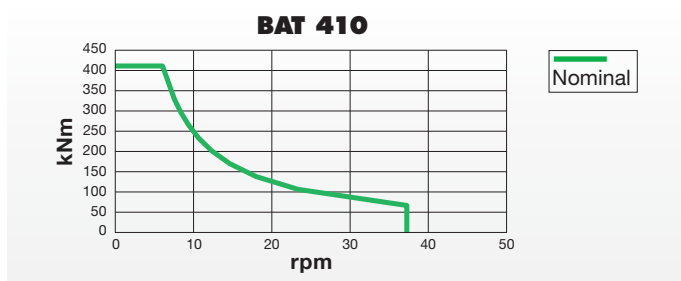

Kelly drilling

LB 36-410

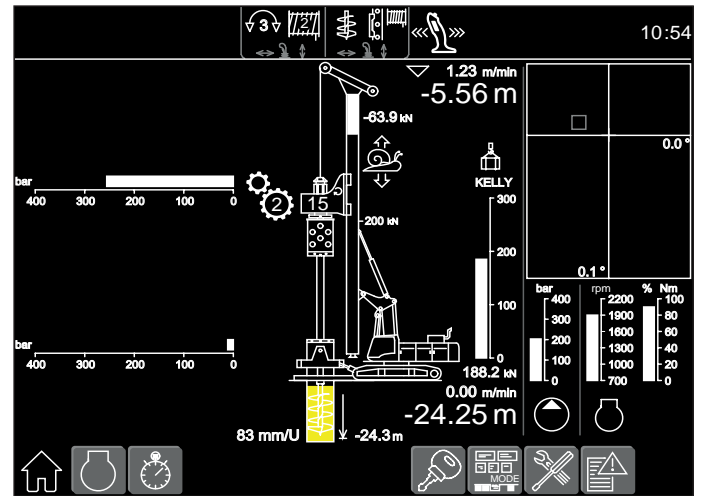

Display for Kelly drilling

Technical data

Rotary drive - torque	0 – 410 kNm
Rotary drive - speed	0 – 37 rpm

Performance data

Max. drilling diameter*	2300 mm uncased
Max. drilling diameter*	2000 mm cased

*) Other drilling diameters available on request

Kelly bars

	A	X	Drilling depth	Weight	Kelly Ø
	(mm)	(mm)	(m)	(t)	(mm)
MD 36/3/30	11900	9800	28.0	7.6	470
MD 36/3/36	13900	7800	34.0	8.8	470
MD 36/4/42	12950	8700	40.0	10.3	470
MD 36/4/48	14450	7200	46.0	11.5	470
MD 36/4/54	15950	5700	52.0	12.7	470
MD 36/4/60	17450	4200	58.0	13.9	470
MD 36/4/66	18950	2700	64.0	15.1	470

Other Kelly bars available on request

When using a casing oscillator, value X has to be reduced by 1600 mm.

Kelly drilling

LB 36-410 with optional equipment

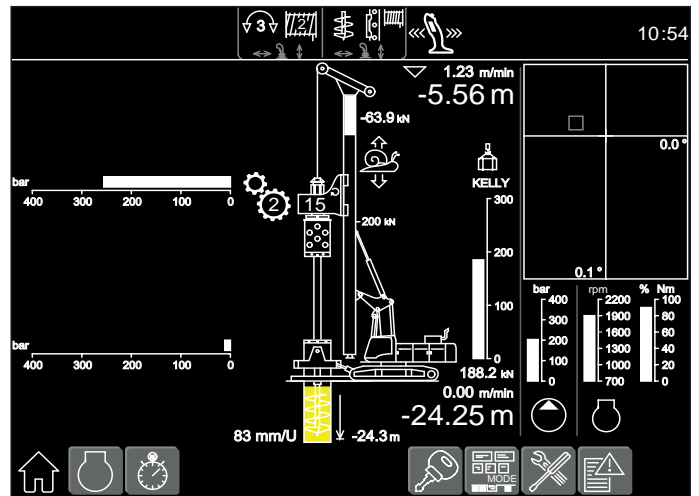

Display for Kelly drilling

Technical data

Rotary drive - torque	0 – 410 kNm
Rotary drive - speed	0 – 37 rpm

Performance data

Max. drilling diameter*	3000 mm uncased
Max. drilling diameter*	2500 mm cased

*) Other drilling diameters available on request

Other Kelly bars available on request

When using a casing oscillator, value X has to be reduced by 1600 mm.

Kelly bars

	A	X	Drilling depth	Weight	Kelly Ø
	(mm)	(mm)	(m)	(t)	(mm)
MD 36/3/30	11900	11100	28.0	7.6	470
MD 36/3/36	13900	9100	34.0	8.8	470
MD 36/4/42	12950	10100	40.0	10.3	470
MD 36/4/48	14450	8600	46.0	11.5	470
MD 36/4/54	15950	7100	52.0	12.7	470
MD 36/4/60	17450	5600	58.0	13.9	470
MD 36/4/66	18950	4100	64.0	15.1	470
MD 36/4/72	20450	2600	70.0	16.3	470
MD 28/5/78	18250	4900	76.0	14.0	508
MD 28/5/84	19450	3700	82.0	15.0	508
MD 28/5/90	20650	2400	88.0	16.8	508

Double rotary drilling

Model DBA 200

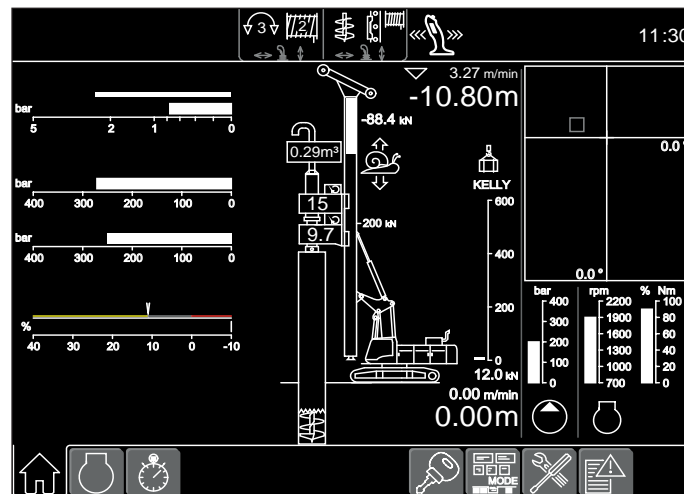

Display for double rotary drilling

Technical data

Rotary drive I - torque	0 – 210 kNm
Rotary drive I - speed	0 – 17 rpm
Rotary drive II - torque	0 – 105 kNm
Rotary drive II - speed	0 – 37 rpm

Performance data

Max. drilling diameter*	750 mm
Max. drilling depth**	17.8 m
Max. pull force	900 kN

*) Other drilling diameters available on request

**) Other drilling depths available on request

Continuous flight auger drilling



Auger with auger guide

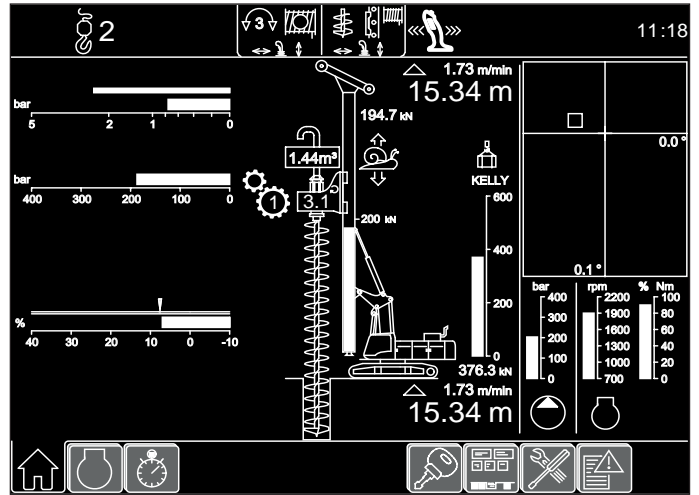

Display for continuous flight auger drilling

Technical data

Rotary drive - torque	0 – 410 kNm
Rotary drive - speed	0 – 37 rpm

Performance data

Drilling depth with auger cleaner*	17.3 m
Drilling depth with 8 m Kelly extension with auger cleaner	25.3 m
Max. pull force (crowd winch and Kelly winch)	1000 kN
Max. push force (weight of rotary and auger to be added)	200 kN
Max. drilling diameter**	1200 mm

*) Without Kelly extension

**) Other drilling diameters available on request

Full displacement drilling

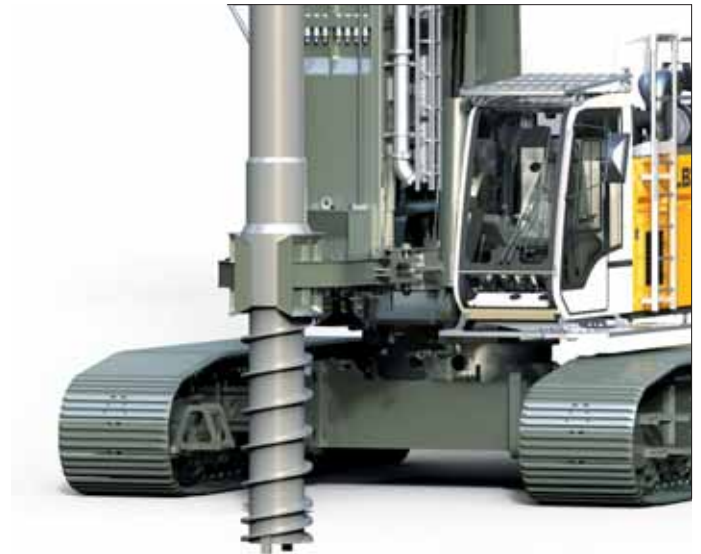

Full displacement tool with auger guide

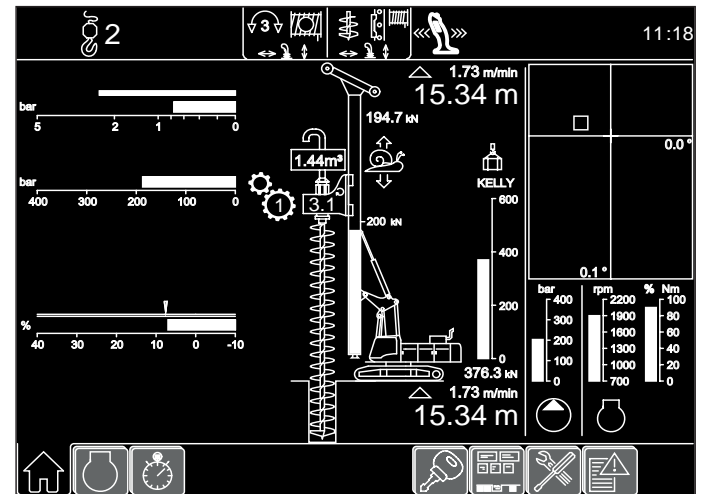

Display for full displacement drilling

Technical data

Rotary drive - torque	0 – 410 kNm
Rotary drive - speed	0 – 37 rpm

Performance data

Drilling depth*	17.8 m
Drilling depth with 8 m Kelly extension	25.8 m
Max. pull force (crowd winch and Kelly winch)	1000 kN
Max. push force (weight of rotary and drilling tool to be added)	200 kN
Max. drilling diameter**	600 mm

*) Without Kelly extension

**) Other drilling diameters available on request

Technical description



Engine

Power rating according to ISO 9249, 390 kW (523 hp) at 1700 rpm
Engine type _____ Liebherr D 946 A7-04
Fuel tank _____ 700 l capacity with continuous level indicator and reserve warning
Engine complies with 97/68 EC Stage IV and NRMM exhaust certification EPA/CARB Tier 4f.



Hydraulic system

The main pumps are operated by a distributor gearbox. Axial piston displacement pumps work in open circuits supplying oil only when needed (flow control on demand).
The hydraulic pressure peaks are absorbed by the integrated automatic pressure compensation, which relieves the pump and saves fuel.

Pumps for working tools _____ 2x 350 l/min
Separate pump for kinematics _____ 180 l/min
Hydraulic oil tank _____ 800 l
Max. working pressure _____ 350 bar

The cleaning of the hydraulic oils occurs via an electronically monitored pressure and return filter.
Any clogging is shown on the display in the cab.
The use of synthetic environmentally friendly oil is also possible.



Crawlers

Propulsion through axial piston motor, hydraulically released spring loaded multi-disc brake, maintenance-free crawler tracks, hydraulic chain tensioning device.

Drive speed _____ 0 – 1.6 km/h
Track force _____ 814 kN
Width of 3-web grousers _____ 1000 mm

Option:
Width of 3-web grousers _____ 900 mm
Transport width _____ 3500 mm
2-speed hydraulic motor for higher travel speed



Noise emission

Noise emissions correspond with 2000/14/EC directive.
Guaranteed sound pressure level L_{PA} in the cabin _____ 78.3 dB(A)
Guaranteed sound power level L_{WA} _____ 112 dB(A)
Vibration transmitted to the hand-arm system of the machine operator _____ $< 2.5 \text{ m/s}^2$
Vibration transmitted to the whole body of the machine operator _____ $< 0.5 \text{ m/s}^2$



Swing

Consists of triple-row roller bearing with external teeth and two swing drives, fixed axial piston hydraulic motor, spring loaded and hydraulically released multi-disc holding brake, planetary gearbox and pinion.
Selector for 3 speed ranges to increase swing precision.
Swing speed from 0 – 2 rpm is continuously variable.



Control

The control system – developed and manufactured by Liebherr – is designed to withstand extreme temperatures and the many heavy-duty construction tasks for which this machine has been designed. Complete machine operating data are displayed on a high resolution monitor screen. A GSM/GPRS telematics module allows for remote inquiry of machine data and operational conditions. To ensure clarity of the information on display, different levels of data are shown in enlarged lettering and symbols.

Control and monitoring of the sensors are also handled by this high technology system. Error indications are automatically displayed on the monitor in clear text. The machine is equipped with proportional control for all movements, which can be carried out simultaneously.
Two joysticks are required for operation. Pedal control can be changed to hand control.

Option:
PDE®: Process data recording



Kelly winch with freewheeling

Line pull effective (1st layer) _____ 300 kN
Rope diameter _____ 34 mm
Line speed _____ 0-76 m/min

Option:
Line pull effective (1st layer) _____ 400 kN
Rope diameter _____ 38 mm
Line speed _____ 0-64 m/min



Auxiliary winch

Line pull effective (1st layer) _____ 100 kN
Rope diameter _____ 20 mm
Line speed _____ 0-89 m/min



Rope crowd system

Crowd force push/pull _____ 400/400 kN
Line pull (effective) _____ 200 kN
Rope diameter _____ 28 mm
Travel with standard leader between mechanical limit stops, without extension _____ 18.5 m
Line speed _____ 0-70 m/min
The winches are noted for compact, easily mounted design. Propulsion is via a maintenance-free planetary gearbox in oil bath. Load support by the hydraulic system; additional safety factor by a spring-loaded, multi-disc holding brake. All line pull values are effective values. The efficiency factor of approx. 25% has already been deducted.

Process data recording system - PDE® (additional equipment)

The Liebherr process data recording system PDE® constantly records the relevant process data during the working process.

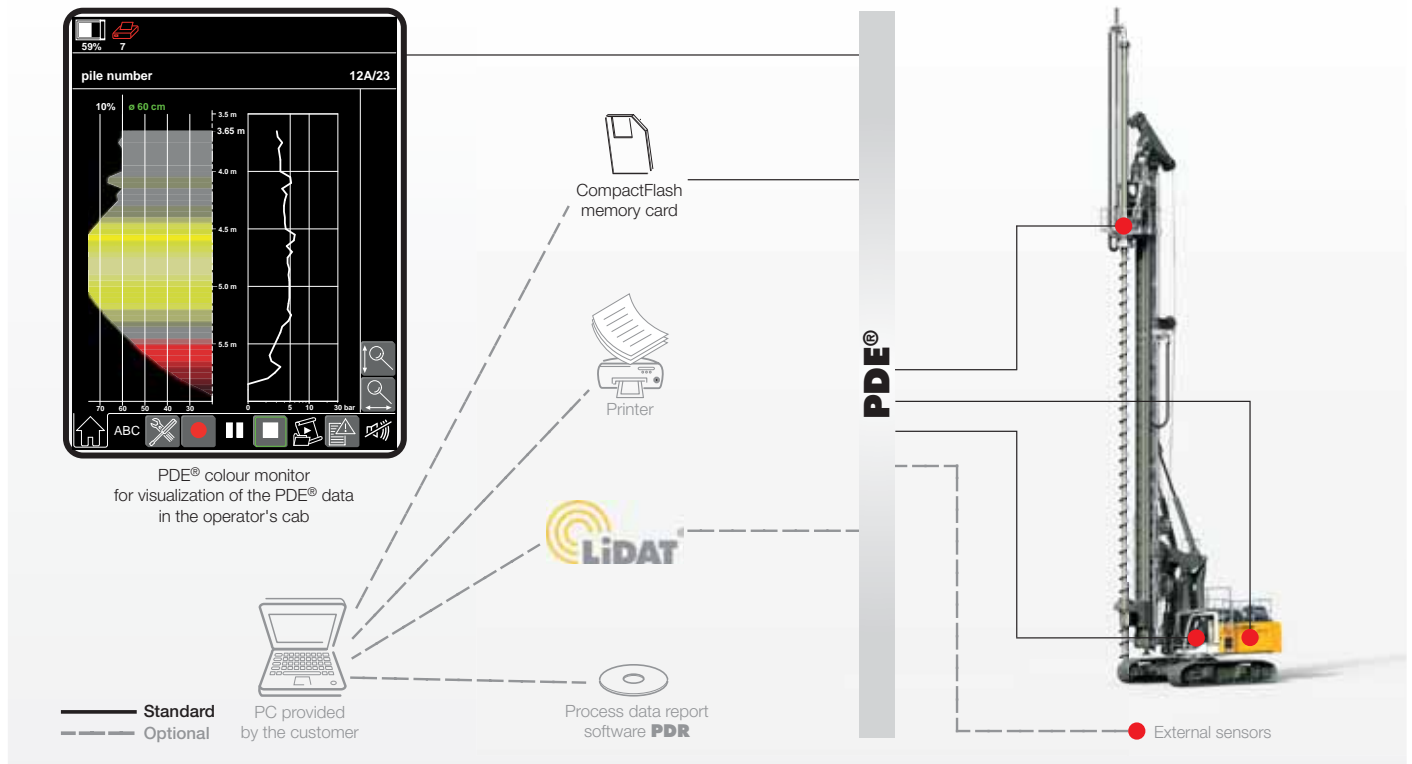

Depending on the application the recorded and processed data are displayed on the PDE® touchscreen in the operator's cab, e.g. in the form of an online cast-in-place pile.

At the same time the PDE® is operated using this touchscreen. The operator can enter various details (e.g. jobsite name, pile number, etc.) and start and stop recordings. A recording of every start-stop cycle carried out in the PDE® is established on a CompactFlash memory card.

The PDE® can be configured in a number of ways, e.g. for the connection of external sensors, for the generation of a simple protocol as graphic file and/or for a printout directly in the operator's cab.

Process data reporting - PDR (additional equipment)

Comprehensive data evaluation and generation of reports on a PC is possible using the software PDR.

Recordings management - The recordings generated by the PDE® system can be imported and managed in PDR. The data can be imported directly from the CompactFlash card or via the Liebherr telematics system LiDAT. Certain recordings, e.g. for a particular day or jobsite, can be found using filter functions.

Viewing data - The data in each record is displayed tabularly. Combining several recordings provides results, for example, regarding the total concrete consumption or the average depth. Furthermore, a diagram editor is available for quick analysis.

Generating reports - A vital element of PDR is the report generator, which allows for the generation of individual reports. These can be printed out directly or stored as pdf files. In the process the size, colour, line thickness or even the desired logo can be configured. Moreover, the reports can be displayed in different languages, e.g. in English and in the national language.

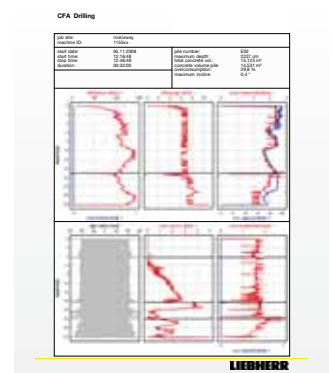

Liebherr-Werk Nenzing GmbH

Dr. Hans Liebherr Str. 1, 6710 Nenzing/Austria
Tel.: +43 50809 41-473, Fax: +43 50809 41-499
crawler.crane@liebherr.com, www.liebherr.com
facebook.com/LiebherrConstruction